

Yoke Shaft Guide Repair and Replacement Manual Fifth Wheels

FW35-03344 / XA-351-03505 and FW67-16B/XA-351-UB Series Fifth Wheel

Introduction

This manual provides you information necessary to properly repair and replace the yoke shaft guide on your FW35-03344/XA-351-03505 series top plates, and FW67-16B/XA-351-UB elevating fifth wheel top plates.

NOTE: For Holland Fifth Wheel replacement components contact SAF-HOLLAND Customer Service: 888-396-6501.

Warranty

Refer to the complete warranty for the country in which the product will be used. A copy of the written warranty was included with the fifth wheel and can also be found on the SAF-HOLLAND Web Site (www.safholland.us).

Notes, Cautions, and Warnings

You must read and understand all of the procedures presented in this manual before starting work on any Holland fifth wheel.

NOTE: In the United States, work shop safety requirements are defined by federal and/or state Occupational Safety and Health Act. Equivalent laws may exist in other countries. This manual is written based on the assumption that OSHA or other applicable employee safety regulations are followed by the location where work is performed.

IMPORTANT: Read this manual before using this product. Keep this manual in a safe location for future reference.

WARNING Failure to follow all the repair procedures contained in this manual could cause a hazardous condition to develop which, if not avoided, could result in death or serious injury.

Proper tools must be used to perform the rebuild procedures described in this manual.

Throughout this manual, you will notice the terms "NOTE", "IMPORTANT", "CAUTION", and "WARNING", followed by useful product information. So that you may better understand the manual, those terms are as follows:

NOTE: Includes additional information to enable accurate and easy performance of procedures.

IMPORTANT: Includes additional information that if not followed could lead to hindered product performance.

CAUTION

Used without the safety alert symbol, indicates a potentially hazardous situation which, if not avoided, could result in property damage.

CAUTION

Indicates a potentially hazardous situation which, if not avoided, could result in minor or moderate injury.

WARNING

Indicates a potentially hazardous situation which, if not avoided, could result in death or serious injury.



1. Model Identification

This manual contains yoke shaft guide repair and replacement procedures for SAF-HOLLAND repair kit RK-351-YSGUIDE. Before repairing, verify that you have the correct kit for the fifth wheel top plate you are attempting to repair. The fifth wheel part number tag is located on the side of the fifth wheel "pick-up" ramp (**Figure 1**).

NOTE: Before repairing your Holland Fifth Wheel review the model number on the identification tag. This repair procedure applies only to the FW35-03344/XA-351-03505 and FW67-16B/XA-351-UB elevating fifth wheel top plates.

2. General Safety Instructions

Read and observe all Warning and Caution hazard alert messages in this publication. They provide information that can help prevent serious personal injury, damage to components, or both.

All fifth wheel repair and maintenance must be performed by a trained technician using proper tools and safe procedures.

⚠ WARNING Failure to properly repair and install the fifth wheel could adversely affect performance resulting in tractor trailer separation which, if not avoided, could result in death or serious injury.

We recommend only the use of SAF-HOLLAND Original Parts.

A list of SAF-HOLLAND technical support locations to supply SAF-HOLLAND Original Parts can be found at www.safholland.us or contact our customer service group at 888-396-6501.

Updates to this manual will be published as necessary on the Internet at www.safholland.us.

Figure 1

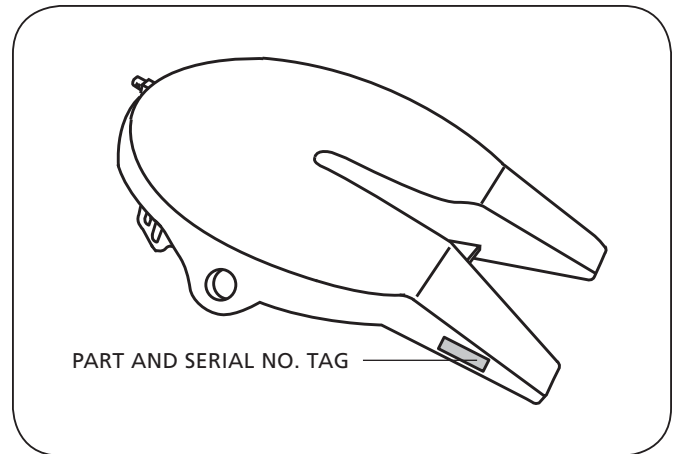

Kit Contents and Top Plate Removal



SAF-HOLLAND Group

3. Kit Contents (Figure 2)

ITEM	DESCRIPTION	PART NUMBER	QTY.
1	Cam Roller	XA-1507-1	1
2	Yoke Shaft	XA-1706-1	1
3	HHCS, 5/8" -18 x 2"	XB-10035	1
4	HHSC 1/2" -20 x 1-3/4"	XB-T-89-5	1
5	Cam Spacer	XA-09040	1
6	Washer - Special	XB-1030	1
7	Washer - 1/2"	XB-PW-1732-1-116	1
8	Washer	XB-08559	1
9	Lock Nut - 1/2" - 20 GRC	XB-T-69-A	2
10	Washer	XB-07431	1
11	HHCS, 1/2" -20 x 1-3/4"	XB-2083	1
12	Yoke Shaft Guide	XA-1709-D	1
13	Roller	XA-1029	1

Figure 2

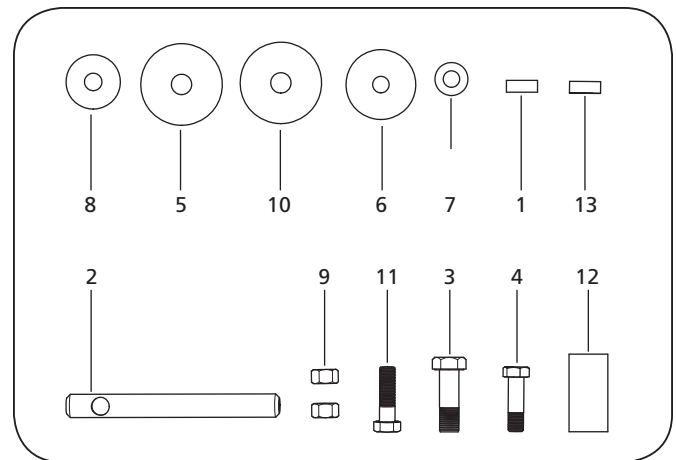

4. Top Plate Removal

1. Clean off excessive grease, grime, and dirt from top plate.
2. Remove bracket pin roll pins from both sides of fifth wheel top plate (**Figure 3**).
3. Using a pry bar, pull bracket retention pins out of fifth wheel top plate (**Figure 3**).
4. Using a lifting device capable of lifting 500 lbs. (227 kg), remove top plate from mounting base. Place fifth wheel upside down on a flat, clean working area.

NOTE: Follow instructions published by lifting device manufacturer for proper operation of lifting device.

IMPORTANT: This procedure will result in several parts of your fifth wheel being replaced. "NEW" parts are included in the kit that came with this procedure. DO NOT reuse "OLD" parts that were removed during disassembly.

NOTE: Bracket pins may be difficult to dislodge and may require force to remove.

CAUTION Do not hit steel parts with a steel hammer as parts could break, sending flying steel fragments in any direction creating a hazard which, if not avoided, could result in minor to moderate injury.

Figure 3

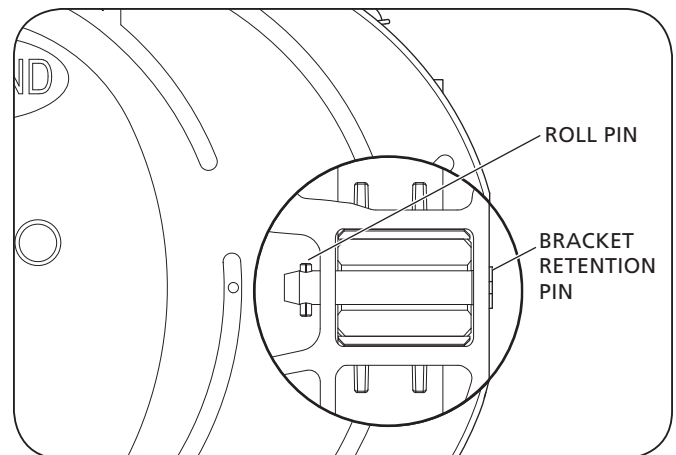

5. Repair Procedures

IMPORTANT: When welding use a procedure and filler metal with a sound, good quality weld which protects the welding operator and others. An AWS E70XX or E60XX filler metal, used in conjunction with either GMW (gas shield solid wire, FCAW (gas shield flux core wire), or SMAW (AC or DC stick) is recommended.

WARNING Over welding may cause distortion or damage and under welding may not develop sufficient strength. Failure to follow proper weld procedures could cause failure/fracture which could result in equipment malfunction.

Disassembly of Cam Plate & Yoke shaft

1. Place top plate with bottom side up in a safe area.
2. Remove the 5/8" yoke bolt, 2-5/8" O.D. washer, 5/8" cam roller, cam spacer, 1/2" cam bolt, 2-1/4" O.D. washer, 1/2" roller, 1-3/4" O.D. washer, and 1/2" nut (**Figure 4**). Discard these components.
3. Remove 1/2" bolt, 1/2" nut and 1" O.D. washer from the cam to air cylinder clevis (**Figure 4**). Discard these components.
4. Remove the cam plate and release handle with washers and spring and put aside for reassembly. Move the air cylinder out of the way (**Figure 4**).
5. Remove the yoke shaft by pushing it out the front of the top plate (**Figure 4**).
6. Remove the yoke spring from assembly (**Figure 4**).

Figure 4

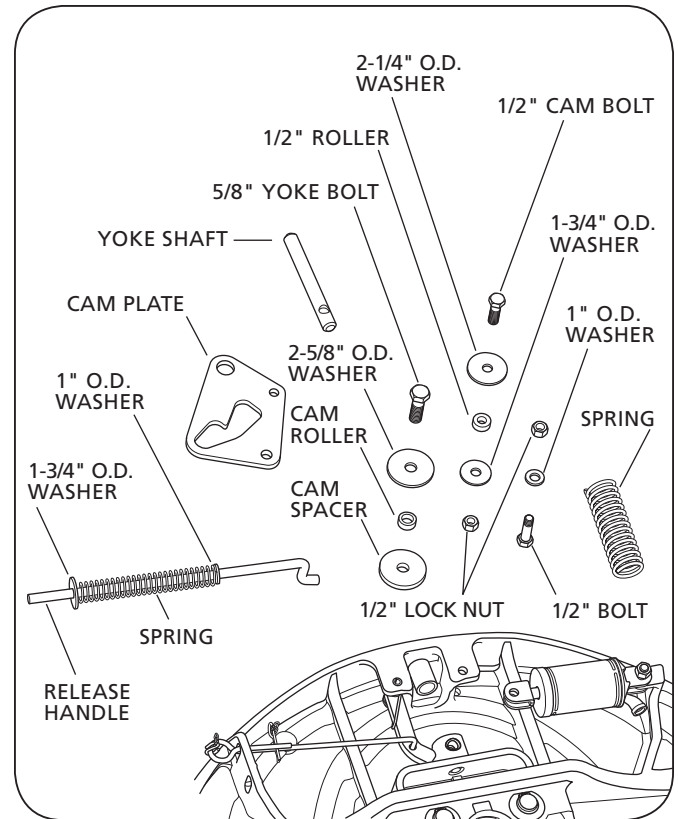

Removing Existing Yoke Shaft Guide and Install New

1. Remove existing guide from fifth wheel by saw cutting or grinding and discard.
2. Grind flush any residual weld on the inside of the casting skirt.
3. Machine yoke shaft hole with drill or mill in casting skirt to 1.26" (31.8 mm) diameter $+.06"$ / $-.00"$.

NOTE: If Yoke shaft hole is machined undersize the XA-1709-D replacement guide will not fit since it has a 1.26" (31.88 mm) outside diameter (**Figure 6**). If machined oversize it will be difficult to center, properly align, and fill in with weld.

4. Prior to sliding the new guide into position grind away any paint or rust within 1/2" around the hole in the skirt. Remove only paint and rust DO NOT chamfer or otherwise reduce the thickness of the skirt.
5. Position the guide into the hole in the skirt with .25" (6.3 mm) protruding outside the casting skirt. Align the guide so it is square to the king pin center line and level. Use the old yoke shaft as a guide; apply a light amount of grease before inserting into guide (**Figure 7**).

WARNING New yoke shaft guide must be center aligned so the yoke shaft does not bind or jam once in use. Binding or jamming of the yoke shaft will cause improper operation of the fifth wheel.

NOTE: New yoke shaft guide must be center aligned so yoke shaft does not jam once in use.

6. Once proper positioning is achieved, clamp the yoke shaft guide in place (spring clamp etc.) to keep it from moving (**Figure 7**).
7. Apply tack welds to outside of the casting to the guide (**Figure 7**).
8. Remove clamping device(s) and finish with .25" (6.3 mm) fillet weld all around the outside of the tube on the outside of casting skirt (**Figure 7**).
9. After cooling remove the Old Yoke Shaft that was used as a guide.

Figure 5

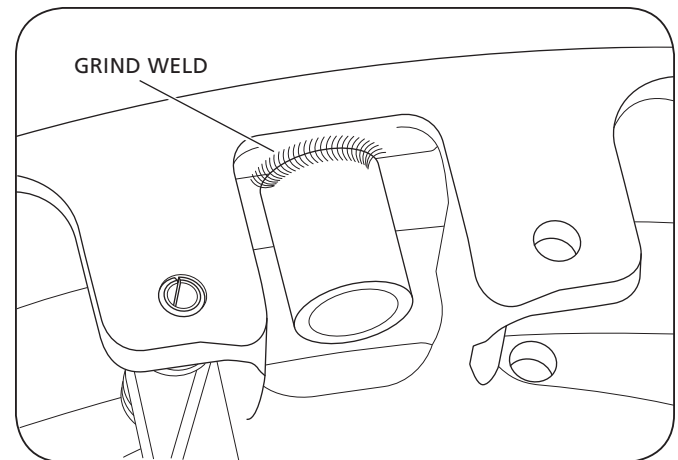

Figure 6

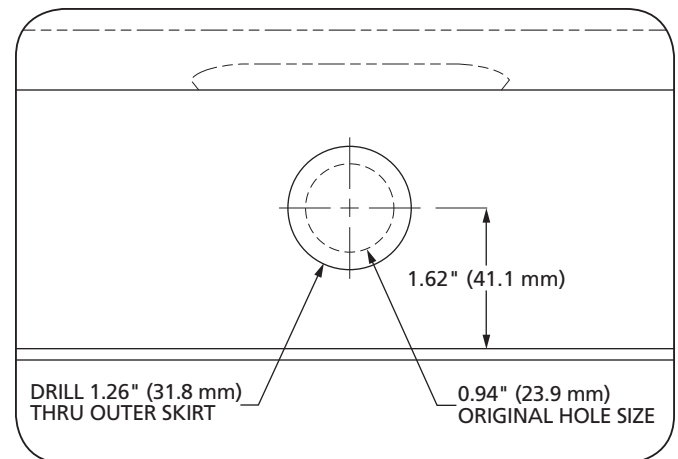
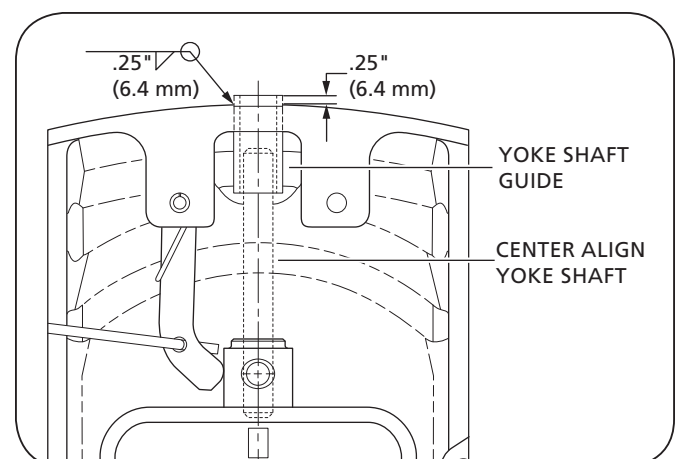

Figure 7



6. Assembly

1. Install the yoke spring by first placing onto the guide and then compressing and pushing the other end onto the yoke (**Figure 8**).
2. Slide the new yoke shaft into the casting through the guide and the spring and into the yoke. Align the recessed hole in the shaft with the threaded hole in the yoke.
3. In this order, slide the 1" O.D. washer, rod spring, and 1-3/4" O.D. washer onto the release rod (**Figure 9**).
4. Slide the straight end of the release rod through the inside of the casting window, or handle guide (**Figure 9**).
5. Insert the "S" bend of the release handle rod into the hole in the cam plate (**Figure 9**).
6. Position the cam plate pivot hole over the casting lug. Slide a 1-3/4" washer between the cam plate and the casting lug with the rounded side of the washer facing the cam plate (**Figure 9**).

NOTE: When installing washers, the rounded edge of the washers face the cam plate.

7. Install the 1/2" I.D. roller into the cam plate and place a 2-1/4" O.D. washer on top of the roller with the rounded side facing the cam plate (**Figure 9**).
8. Install the 1/2" bolt through the washers, roller, and top plate lug (**Figure 9**).
9. Secure the bolt with a 1/2" nut. Torque to 60-70 ft.-lbs. (81-94 N•m). Then check for free movement of the cam plate (**Figure 9**).
10. Align the cam plate track over the threaded hole in the yoke (**Figure 10**).
11. Slide the 2-5/8" O.D. x 3/8" spacer between the yoke and cam plate (**Figure 10**).
12. Place the 5/8" I.D. roller, into the cam plate track, then place the 2-5/8" O.D. washer over the roller with the rounded side of the washer facing the cam plate (**Figure 10**).
13. Check the alignment of the recessed hole in the yoke shaft (**Figure 11**).
14. Install the 5/8" bolt through the washers, roller and

Figure 8

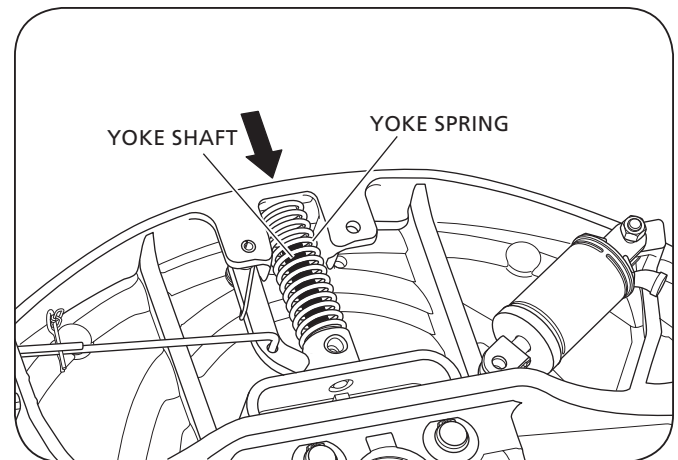

Figure 9

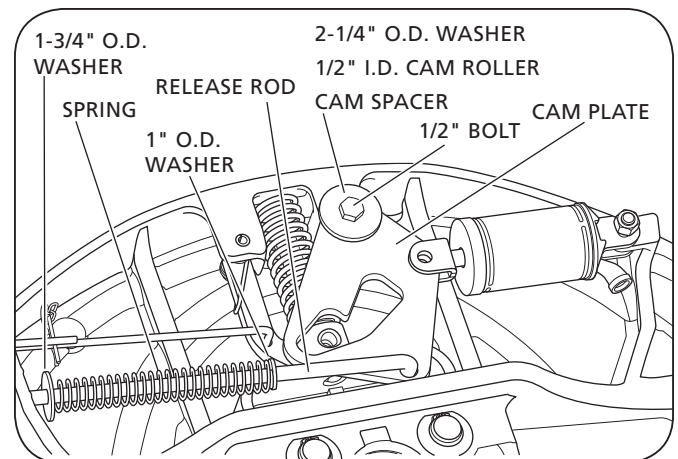
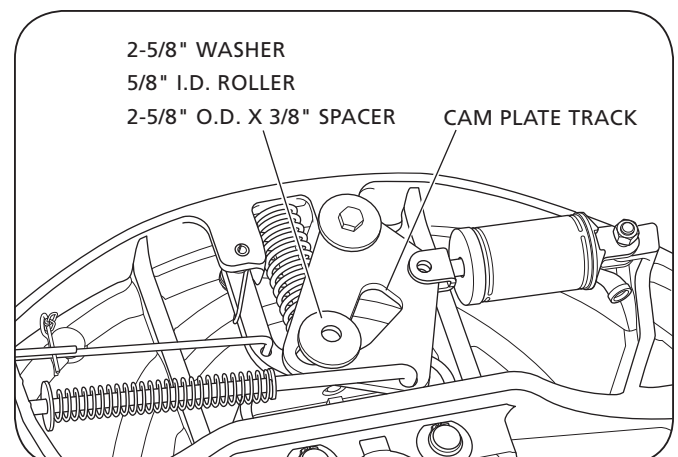

Figure 10



cam plate and into the threaded hole in the yoke. Make sure the bolt enters the recessed hole in the yoke shaft (**Figure 11**).

15. Tighten the bolt securely into the yoke and shaft (the bolt cuts threads into the shaft and therefore there is not a set torque value). Make sure the gap between the washer and cam plate is between .06" (1.52 mm) and .120" (3.04 mm). Then check for free movement of the cam plate and nut (**Figure 11**).
16. Align cam connection hole with air cylinder clevis and install 1/2" bolt, 1/2" washer and nut. Torque to 60-70 ft.-lbs. (81-94 N•m) (**Figure 12**).
17. Lubricate the cam track, handle spring, and pivot points with a water-resistant lithium-based grease (**Figure 12**).

Figure 11

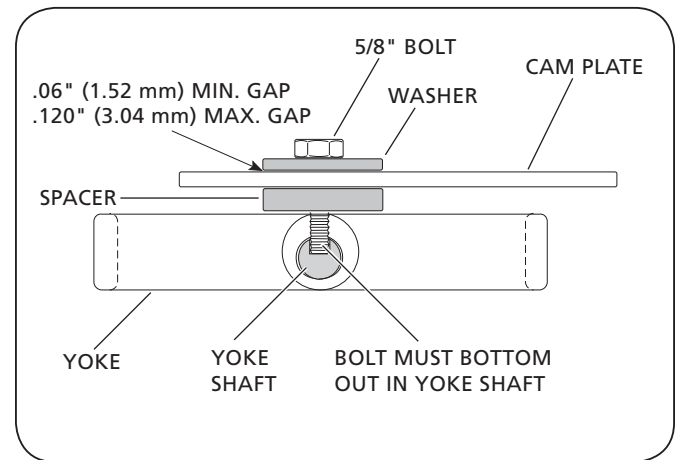
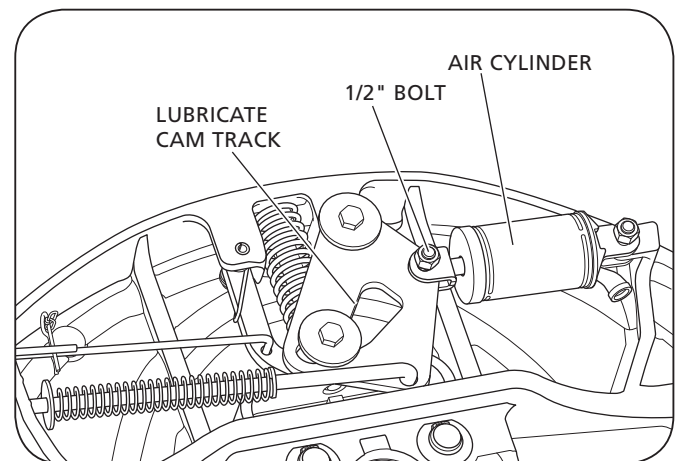

Figure 12



7. Top Plate Installation

Before you use your fifth wheel, you must verify that it, and the control system, are operating properly.

1. Check the air lines for signs of chafing or other damage, check the control valve for proper operation, and make certain the air breather hole on the air cylinder end cap is open (**Figure 13**). Repair as needed.
2. Using a lifting device capable of lifting 500 lbs., (227 kg), install fifth wheel top plate onto its mounting base.

NOTE: Follow instructions published by lifting device manufacturer for proper operation of lifting device.

3. Install bracket pins through fifth wheel casting and mounting base and secure by installing the bracket pin's roll pins (**Figure 14**).
4. Reattach air line.

8. Operation Check

1. Using a Holland lock tester (TF-TLN-5001), close the fifth wheel locks. Verify that the locks are properly closed around the lock tester. Activate the fifth wheel release switch and remove the lock tester. Repeat this step three times to verify proper operation (**Figure 15**).

After three (3) successful operational checks, your fifth wheel is ready for operation.

IMPORTANT: Before using your fifth wheel, visually inspect all components of fifth wheel for proper operation while coupling and uncoupling fifth wheel with lock tester.

⚠ WARNING Failure to repair an improperly operating fifth wheel may result in tractor-trailer separation which, if not avoided, could result in serious injury or death.

IMPORTANT: Be sure to read and understand Fifth Wheel Operation Instructions published in the Fifth Wheel Owner's Manual available on the internet at (www.safholland.us) prior to use.

⚠ WARNING Failure to read and understand Fifth Wheel Operation Instructions prior to use could result in improper operation of fifth wheel which, if not avoided, could result in death or serious injury.

Figure 13

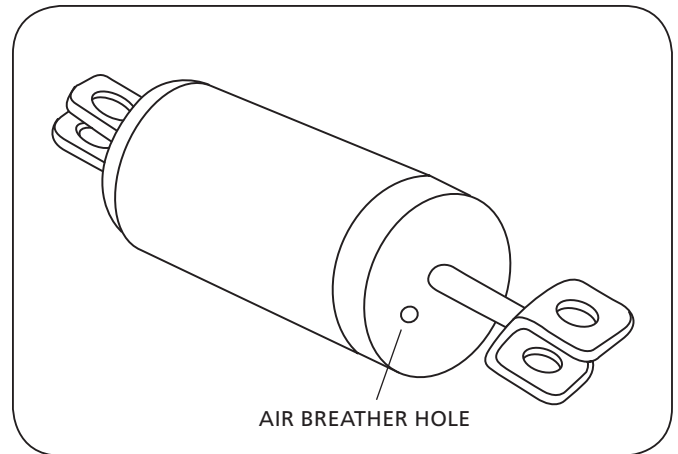

Figure 14

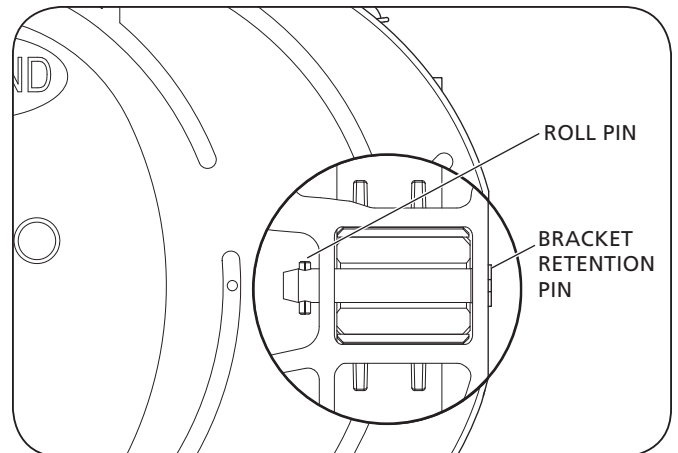

Figure 15

